

K3142 PANEL FEMALE

16A 6h IP67 | 3P+E | 380-415V



Product description

Waterproof 16A panel-mounted female socket with hinged cover, screw terminals, flame-retardant housing and IP67 protection.

Typical applications

Designed and manufactured according to IEC 60309-1/2:2021 and GB/T11918.1/2-2014 for factory power distribution, machinery, construction sites, chemical plants, ports, airports, drainage and wastewater projects.

Product Data

| | | | |
|------------------------------|---------------------------------|---------------------------------|-------------------------------|
| Product type | Panel Female, 16 A | Rated voltage | 380-415 V |
| Rated current | 16 A | Earth Contact Position | 6h |
| Poles | 3P+E, 4-pole | Protection grade | IP67 |
| Withstand voltage | AC 2500 V | Insulation resistance | 500 V d.c. 1 min > 5 Mohm |
| Certification | TUV, CB, CE | Environmental compliance | RoHS; non-RoHS optional |
| Mechanical life | ≥ 50,000 mating cycles, no load | Dimensions | See dimensions drawing |
| Salt spray resistance | > 48 h, no rust | Impact test | -25 C, 16 h, > 0.5 kg, 25 deg |

Materials and Construction

| | | | |
|---------------------------------|--|--------------------------|----------------------|
| Contacts | Brass, Natural copper finish | Contact process | Stamping + machining |
| Housing | Flame-retardant nylon(PA)+ PC glow-wire 650 C | Housing color | Red + white |
| Insert / contact carrier | Flame-retardant nylon PA glow-wire 850 C | Insert color | Rust red |
| Screw accessories | Iron / stainless steel | Surface treatment | Zinc plating |
| Manufacturing | Injection molding for housing and insert | Terminal type | Screw terminal |

Operating, Packing and Compatibility

| | | | |
|------------------------------|--------------------|-----------------|---|
| Operating temperature | -25 C to 125 C | Humidity | 93% at 40 C |
| Compatible products | K014, K0141, K0142 | Packing | Inner: 10 pcs / box; Outer: 60 pcs / carton |

Dimensions (mm)

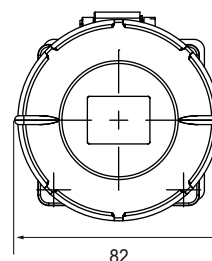
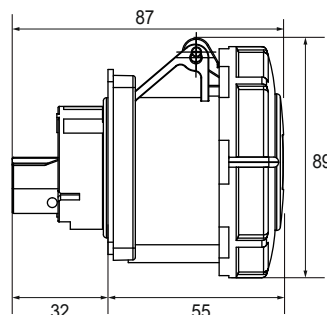
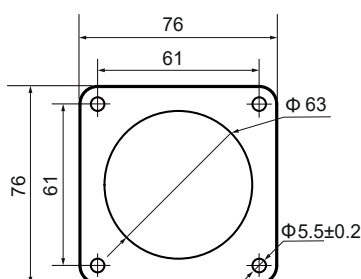

**Cable Nominal
Cross-section
Area (mm²)**

1 - 2.5